

Distributed by:

JAMECO[®]
ELECTRONICS

www.Jameco.com ♦ 1-800-831-4242

The content and copyrights of the attached
material are the property of its owner.

Jameco Part Number 951931

THIS DRAWING IS UNPUBLISHED. RELEASED FOR PUBLICATION
 © COPYRIGHT BY TYCO ELECTRONICS CORPORATION. ALL RIGHTS RESERVED.

LOC	DIST	REVISIONS			
P	LTR	DESCRIPTION	DATE	DWN	APVD
GP	00	0	RELEASED PER EC 0S13-0207-05	27JUN05	SW JG

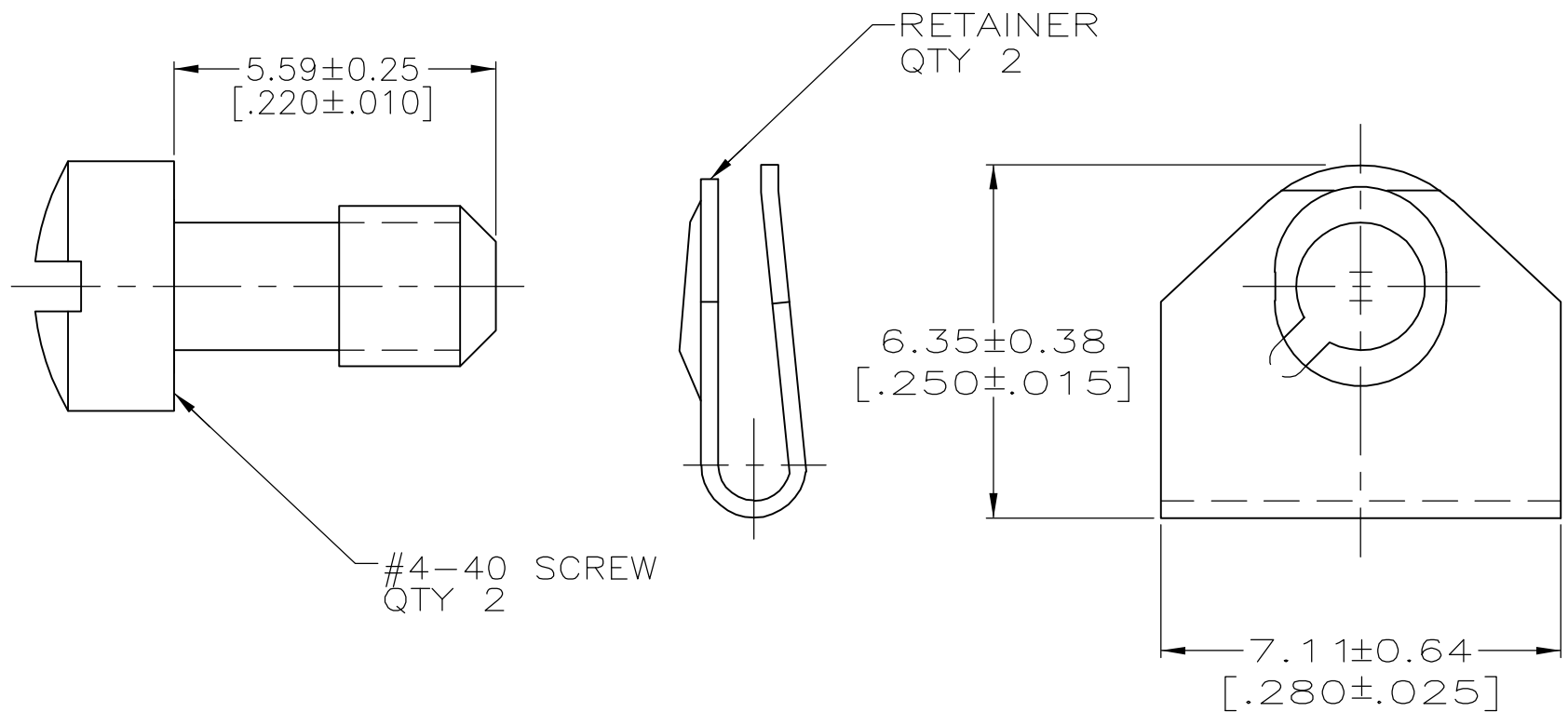

- 1. PARTS PACKAGED UNASSEMBLED.
- 2. STAINLESS STEEL PER ASTM A666.
- 3. PACKAGING MARKED WITH TYCO, PART NO & DATE CODE.
- 4. ZINC PLATED .000200-.000400 THICK YELLOW CHROMATE COATING.
- 5. ZINC PLATED .000200-.000400 THICK CLEAR CHROMATE COATING.
- 6. PARTS INDIVIDUALLY BULK PACKED AND SHIPPED AS A UNIT PACKAGE.
- 7. PARTS PACKAGED AS A UNIT KIT.

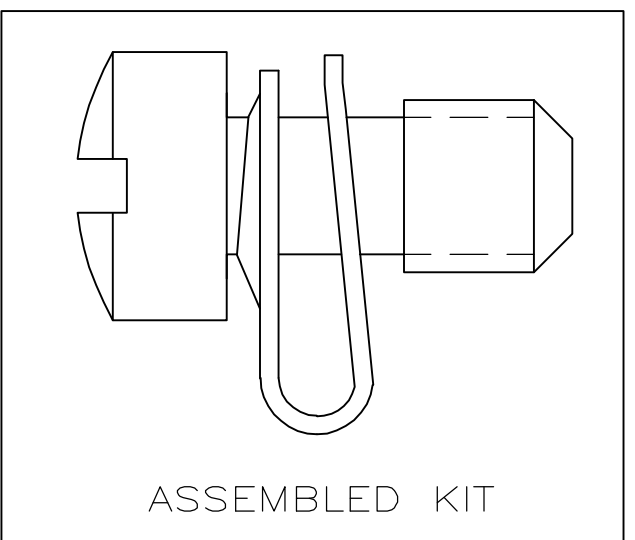

3	6	5	5205980-5
3	7	5	5205980-4
3	6	4	5205980-3
3	7	4	5205980-1
MARKING	PACKAGING	SCREW FINISH	PART NO

THIS DRAWING IS A CONTROLLED DOCUMENT.		DWN S.WAITMAN 27JUN05	Tyco Electronics Corporation Harrisburg, Pa 17105-3608				
DIMENSIONS: mm [INCHES]		CHK C.ROHDE 27JUN05					
TOLERANCES UNLESS OTHERWISE SPECIFIED:		APVD M.WALMSLEY 27JUN05	NAME				
0 PLC ± - 1 PLC ± - 2 PLC ± 0.13 [.005] 3 PLC ± - 4 PLC ± - ANGLES ± -		PRODUCT SPEC	KIT, SCREW RETAINER				
MATERIAL		APPLICATION SPEC	SIZE	CAGE CODE	DRAWING NO	RESTRICTED TO	
SCREWS: CARBON STEEL		FINISH	A3 00779		C-5205980	-	
RETAINERS: 2		SCREWS: -SEE TABLE	CUSTOMER DRAWING		SCALE 8:1	SHEET 1 OF 1	REV 0