

Distributed by:

JAMECO[®]
ELECTRONICS

www.Jameco.com ♦ 1-800-831-4242

The content and copyrights of the attached
material are the property of its owner.

Jameco Part Number 890234

REVOLUTIONS		DATE	APP'D
CM	54	V	REV PER EC 0730-4347-93

D
C
B
A
 8
7
6
5
4
3
2
1

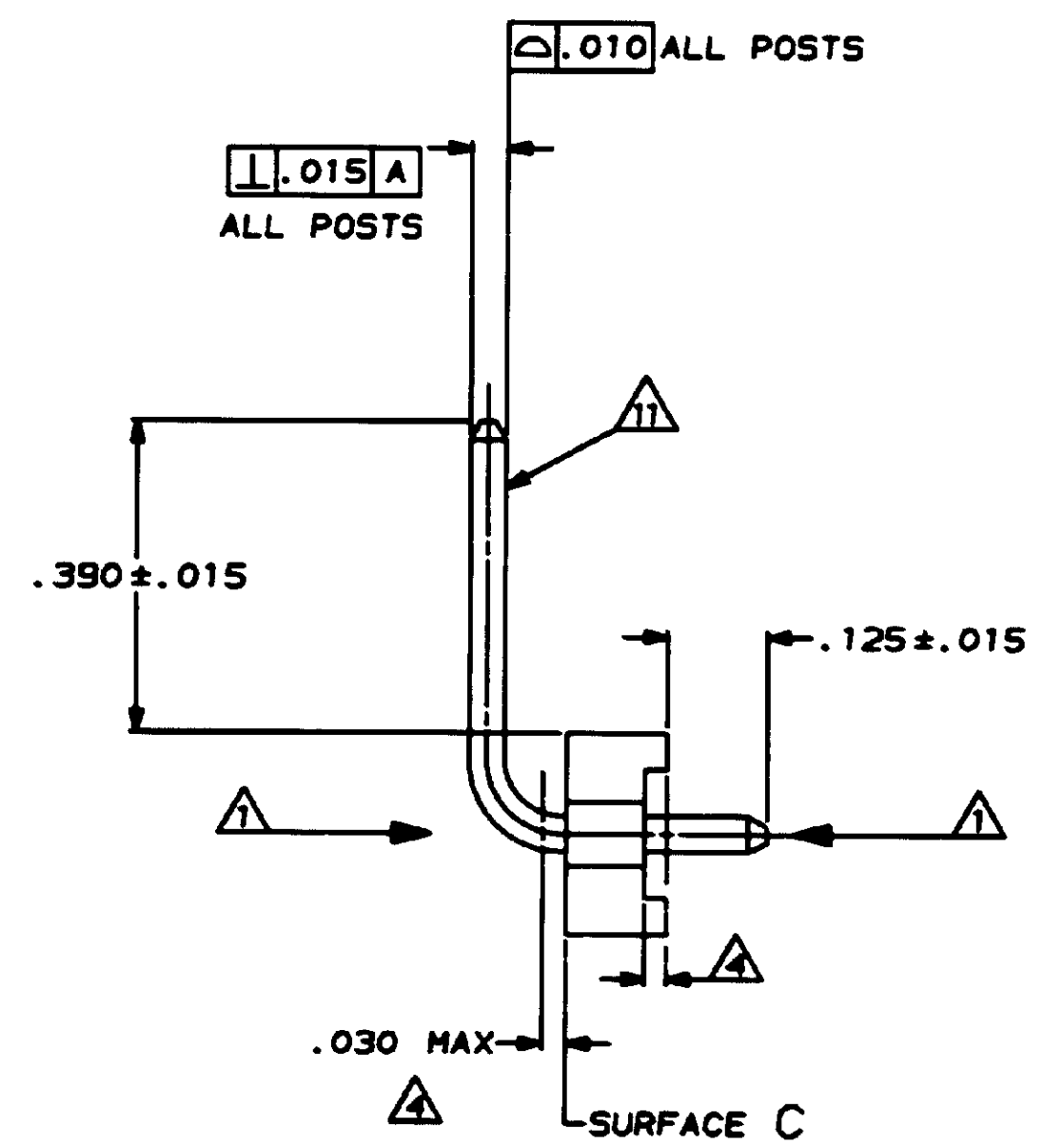
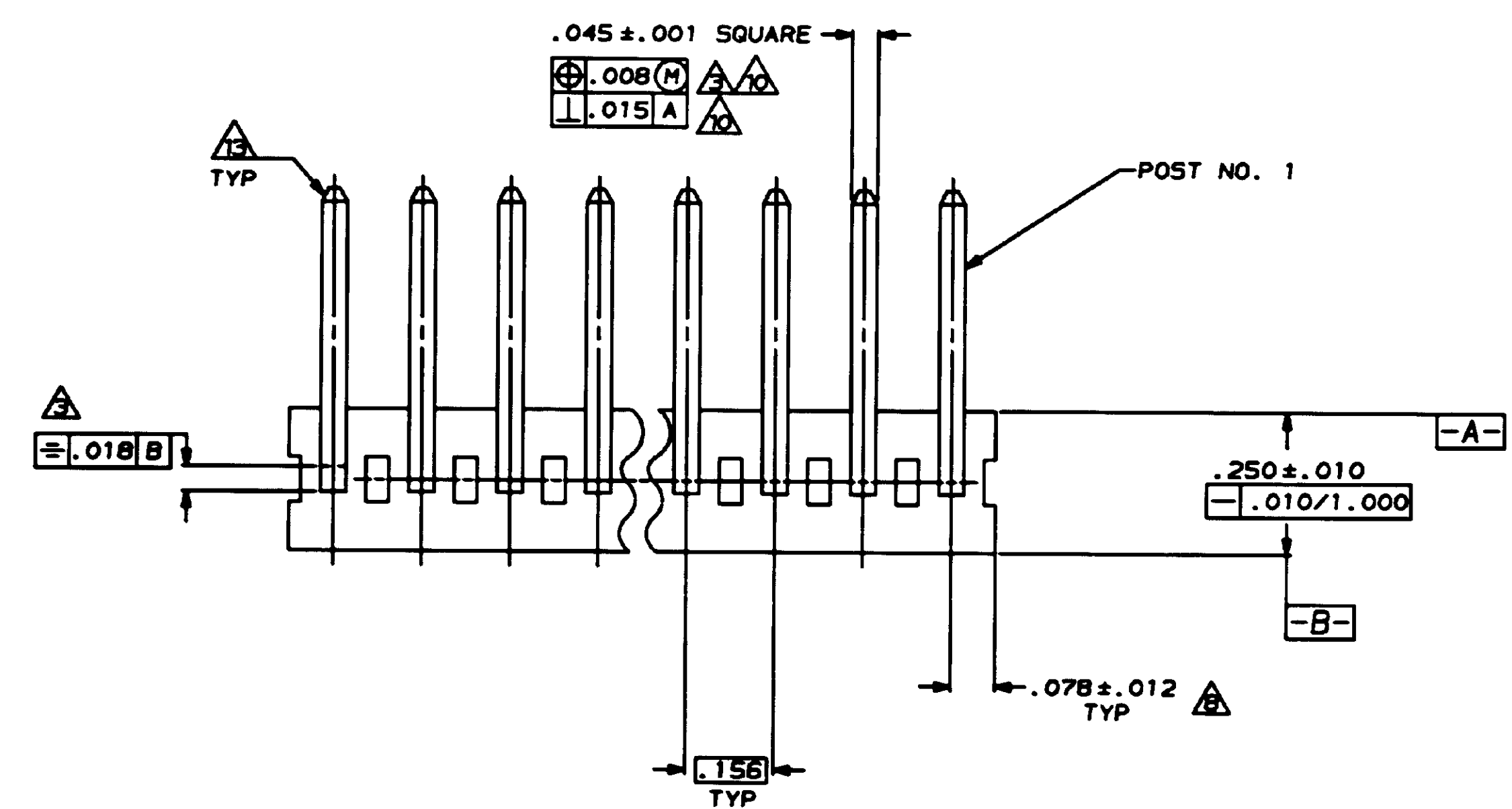
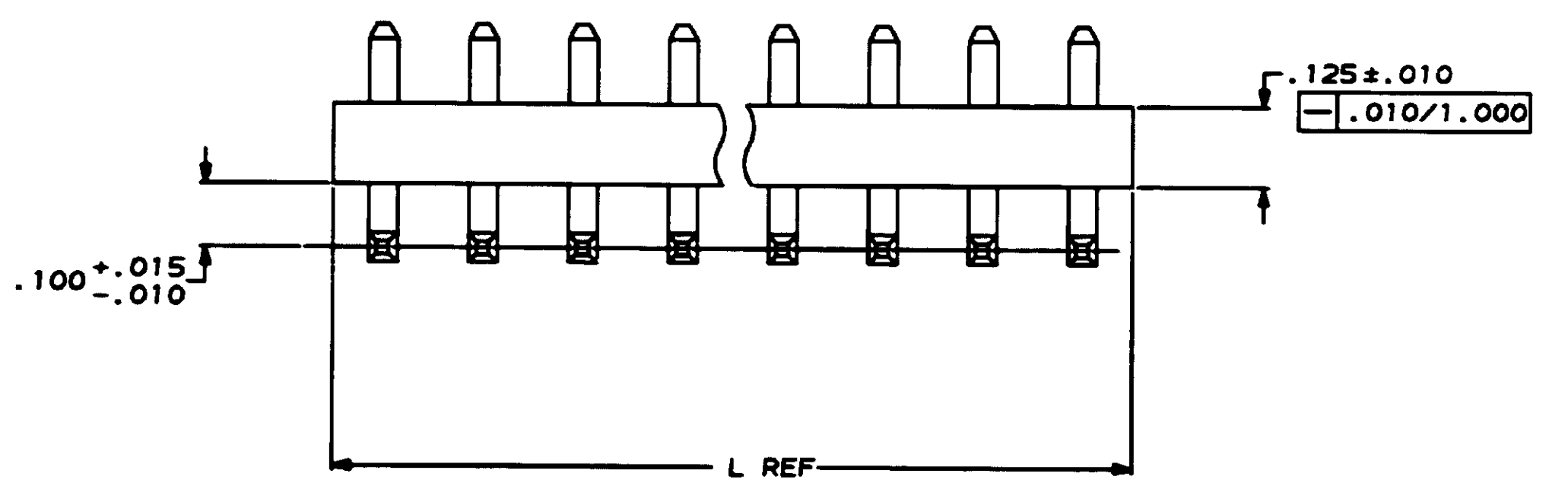

- ⚠ POST TO WITHSTAND 13 NEWTONS (3LBS.) MIN. AXIAL FORCE IN BOTH DIRECTIONS SHOWN WITHOUT DISLODGING.
- ⚠ TOLERANCES APPLY TO SOLDER SIDE OF BOARD.
- ⚠ MEASURED AT SURFACE C.
- ⚠ PLASTIC FLASH PERMITTED IN THIS AREA.
- 5. PARTS COMPLY WITH AMP SOLDERABILITY SPEC. NO. 109-11-2.
- ⚠ ONE HOLE MAY BE UNDERSIZED (.065/.060 DIA.) FOR ASSEMBLY RETENTION DURING WAVE SOLDERING.
- ⚠ MATERIAL: HEADER-THERMOPLASTIC POLYESTER GLASS-FILLED 94V-0 (NATURAL) POST-COPPER ALLOY (TIN PLATED)
- ⚠ COORDINATE DIMENSION APPLIES FROM CENTER OF ACTUAL FEATURE.
- 9. PLASTIC BURRS CAUSED BY CUT-OFF TOOLING ARE PERMITTED WITHIN THE MAXIMUM TOLERANCE ENVELOPE.
- ⚠ POST TO BE MEASURED WHEN STRIP IS HELD FLAT.
- ⚠ POST MUST WITHSTAND TWO 90° BENDS AGAINST EXTRUSION WITHOUT BREAKING.
- ⚠ DIMENSION SHOULD BE .140-.1430 WHEN MATING WITH A MTA 156 CONNECTOR ASSEMBLY, .140 MIN WHEN MATING WITH A SL 156 WIRE-TO-BOARD CONNECTOR ASSEMBLY OR .140-.1475 WHEN MATING WITH A SL 156 BOARD-TO-BOARD CONNECTOR ASSEMBLY.
- ⚠ PIN BURR OF .005 MAX. VERTICAL AND .003 MAX. HORIZONTAL PERMITTED AT POST TIPS ON BOTH ENDS.

IN	MM	NUMBER OF POSITIONS	PART NUMBER
3.744	95.10	24	2-640385-4
3.588	91.14	23	2-640385-3
3.432	87.17	22	2-640385-2
3.276	83.21	21	2-640385-1
3.120	79.25	20	2-640385-0
2.964	75.29	19	1-640385-9
2.808	71.32	18	1-640385-8
2.652	67.36	17	1-640385-7
2.496	63.40	16	1-640385-6
2.340	59.44	15	1-640385-5
2.184	55.47	14	1-640385-4
2.028	51.51	13	1-640385-3
1.872	47.55	12	1-640385-2
1.716	43.59	11	1-640385-1
1.560	39.62	10	1-640385-0
1.404	35.66	9	640385-9
1.248	31.70	8	640385-8
1.092	27.74	7	640385-7
.936	23.77	6	640385-6
.780	19.81	5	640385-5
.624	15.85	4	640385-4
.468	11.89	3	640385-3
.312	7.92	2	640385-2

IN	MM	IN	MM
.065	1.65	-	-
.063	1.60	-	-
.060	1.52	1.000	25.40
.045	1.14	.475	12.07
.030	0.76	.430	10.92
.018	0.46	.390	9.91
.015	0.38	.250	6.35
.012	0.30	.156	3.96
.010	0.25	.140	3.56
.008	0.20	.125	3.18
.005	0.13	.100	2.54
.003	0.08	.078	1.98
.001	0.03	.070	1.78

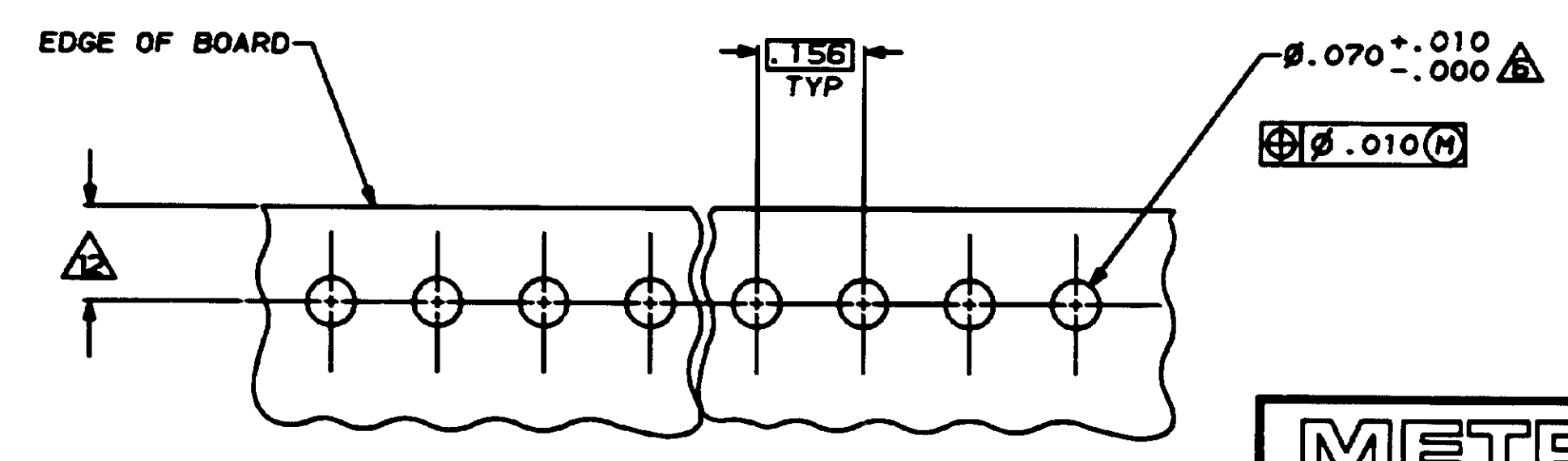

RECOMMENDED MOUNTING HOLE PATTERN FOR .063 THICK P.C. BOARD

METRIC

THIS DRAWING IS A CONTROLLED DOCUMENT FOR AMP INCORPORATED. IT IS SUBJECT TO CHANGE AND THE CONTROLLING ENGINEERING ORGANIZATION SHOULD BE CONTACTED FOR THE LATEST REVISION.

DO NOT SCALE PRINT. UNLESS SPECIFIED DIMENSIONS IN INCHES TOLERANCES ON:		OR 10-15-92 B. LEVITS		PART NO	
1 PLC DEC ± .005	ANGLES ±	CHK 10-15-92 R. SWING	APP'D 1-11-93 R. SPEER	AMP Incorporated Harrisburg, PA 17105-3608	
MATERIAL		APP'D 1-11-93 R. SPEER	PRODUCT SPEC	NAME	
FINISH		APPLICATION SPEC	SIZE	CASE CODE	DRAWING NO
WEIGHT		SCALE	D	00779	C-640385
					SHEET 1 OF 1

MTA-156 HEADER ASSEMBLY, PLAIN, RIGHT ANGLE, .045 SQUARE POST, TIN PLATED

CUSTOMER DRAWING