



Features

- Universal AC input / Full range
- Built-in active PFC function
- Protections: Short circuit / Overload / Over voltage / Over temperature
- 5"x3" compact size
- Free air convection for 110W and 160W with 20.5 CFM forced air
- With power good and fail signal output
- Built-in remote sense function for 5~15V
- No load power consumption under 0.75W by PS-ON control (G model)
- Standby 5V@0.8A with fan, @0.6A without fan (G model)
- 3 years warranty

G: With 5Vsb & no load power consumption < 0.75 W  
 Blank: Basic function (without 5Vsb)

RPS **G** - 160 - 12



SPECIFICATION

MODEL	RPS□-160-5	RPS□-160-12	RPS□-160-15	RPS□-160-24	RPS□-160-48	
OUTPUT	DC VOLTAGE	5V	12V	15V	24V	48V
	RATED CURRENT (20.5CFM)	30A	12.9A	10.3A	6.5A	3.25A
	CURRENT RANGE (convection)	0 ~ 20A	0 ~ 9.1A	0 ~ 7.3A	0 ~ 4.6A	0 ~ 2.3A
	CURRENT RANGE (20.5CFM)	0 ~ 30A	0 ~ 12.9A	0 ~ 10.3A	0 ~ 6.5A	0 ~ 3.25A
	RATED POWER (convection) Note.7	103W	112.2W	112.5W	113.4W	113.4W
	RATED POWER (20.5CFM) Note.8	155W	159.8W	159.5W	161W	161W
	RIPPLE & NOISE (max.) Note.2	100mVp-p	100mVp-p	120mVp-p	150mVp-p	250mVp-p
	VOLTAGE ADJ. RANGE	CH1:4.5 ~ 5.5V	CH1:10.8 ~ 13.2V	CH1:13.5 ~ 16.5V	CH1:22 ~ 27V	CH1:43.2 ~ 52.8V
	VOLTAGE TOLERANCE Note.3	±4.0%	±3.0%	±3.0%	±2.0%	±2.0%
	LINE REGULATION	±0.5%	±0.5%	±0.5%	±0.5%	±0.5%
	LOAD REGULATION	±1.0%	±1.0%	±1.0%	±1.0%	±1.0%
	SETUP, RISE TIME	1200ms, 30ms/230VAC	2500ms, 30ms/115VAC at full load			
HOLD UP TIME (Typ.)	16ms/230VAC/115VAC at full load					
INPUT	VOLTAGE RANGE Note.6	90 ~ 264VAC	127 ~ 370VDC			
	FREQUENCY RANGE	47 ~ 63Hz				
	POWER FACTOR (Typ.)	PF>0.93/230VAC	PF>0.98/115VAC at full load			
	EFFICIENCY (Typ.)	85%	87%	87%	87%	88%
	AC CURRENT (Typ.)	2A/115VAC	1.1A/230VAC			
	INRUSH CURRENT (Typ.)	COLD START 35A/115VAC		70A/230VAC		
LEAKAGE CURRENT	Earth leakage current <300uA / 264VAC, patient leakage current <100uA/264VAC					
PROTECTION	OVERLOAD	105 ~ 135% rated output power Protection type : Hiccup mode, recovers automatically after fault condition is removed				
	OVER VOLTAGE	5.75 ~ 6.75V	13.8 ~ 16.2V	17.25 ~ 20.25V	27.6 ~ 32.4V	55.2 ~ 64.8V
	OVER TEMPERATURE	110°C (5V), 105°C (12V, 15V, 24V, 48V) (TSW1 : detect on heatsink of power transistor)				
		95°C (5V), 90°C (12V, 15V, 24V, 48V) (TSW2 : detect on heatsink of power transistor) Protection type : (TSW1) Shut down o/p voltage, recovers automatically after temperature goes down Protection type : (TSW2) Shut down o/p voltage, re-power on to recover				
FUNCTION	5V STANDBY (G model)	5VSB : 5V@0.6A without fan, 0.8A with fan 20.5CFM ; tolerance ± 2%, ripple : 50mVp-p(max.)				
	PS-ON INPUT SIGNAL (G model)	Power on: PS-ON = "Hi" or "> 2 ~ 5V" ; Power off: PS-ON = "Low" or "< 0 ~ 0.5V"				
	POWER GOOD / POWER FAIL	500ms>PG>10ms	PF>1ms			
	REMOTE SENSE	5 ~ 15V				
ENVIRONMENT	WORKING TEMP.	-20 ~ +70°C (Refer to output load derating curve)				
	WORKING HUMIDITY	20 ~ 90% RH non-condensing				
	STORAGE TEMP., HUMIDITY	-40 ~ +85°C, 10 ~ 95% RH				
	TEMP. COEFFICIENT	±0.03%/°C (0 ~ 50°C)				
	VIBRATION	10 ~ 500Hz, 2G 10min./1cycle, 60min. each along X, Y, Z axes				
SAFETY & EMC (Note 4)	SAFETY STANDARDS	UL60601-1, TUV EN60601-1 approved				
	WITHSTAND VOLTAGE	I/P-O/P:4KVAC	I/P-FG:1.5KVAC	O/P-FG:0.5KVAC		
	ISOLATION RESISTANCE	I/P-O/P, I/P-FG, O/P-FG:100M Ohms / 500VDC / 25°C / 70% RH				
	EMI CONDUCTION & RADIATION	Compliance to EN55011 (CISPR11), EN55022 (CISPR22) Class B				
	HARMONIC CURRENT	Compliance to EN61000-3-2,-3				
EMS IMMUNITY	Compliance to EN61000-4-2,3,4,5,6,8,11; ENV50204, EN55024, EN60601-1-2, EN61204-3, medical level, criteria A					
OTHERS	MTBF	230.5Khrs min. MIL-HDBK-217F (25°C)				
	DIMENSION	127*76.2*34.6mm (L*W*H)				
	PACKING	0.32Kg; 36pcs/12.5Kg/0.79CUFT				
NOTE	<ol style="list-style-type: none"> <li>1. All parameters NOT specially mentioned are measured at 230VAC input, rated load and 25°C of ambient temperature.</li> <li>2. Ripple &amp; noise are measured at 20MHz of bandwidth by using a 12" twisted pair-wire terminated with a 0.1uF &amp; 47uF parallel capacitor.</li> <li>3. Tolerance : includes set up tolerance, line regulation and load regulation.</li> <li>4. The power supply is considered a component which will be installed into a final equipment. The final equipment must be re-confirmed that it still meets EMC directives.</li> <li>5. HS1, HS2 &amp; HS3 can not be shorted.</li> <li>6. Derating may be needed under low input voltages. Please check the derating curve for more details.</li> <li>7. The rated power includes 5Vsb @ 0.6A.</li> <li>8. The rated power includes 5Vsb @ 0.8A.</li> </ol>					

**Mechanical Specification**

Unit:mm

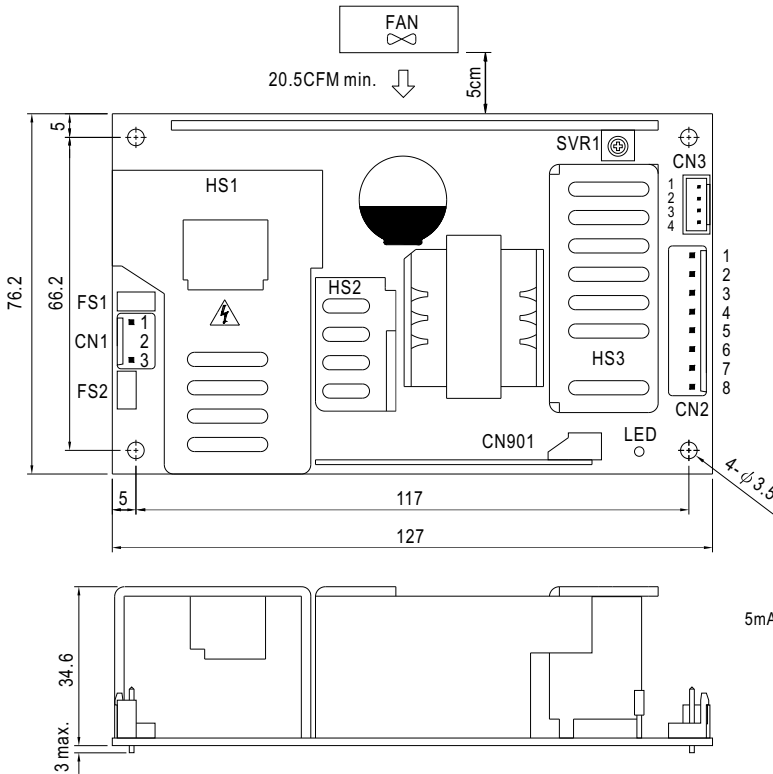

AC Input Connector (CN1) : JST B3P-VH or equivalent

Pin No.	Assignment	Mating Housing	Terminal
1	AC/N	JST VHR or equivalent	JST SVH-21T-P1.1 or equivalent
2	No Pin		
3	AC/L		

DC Output Connector (CN2) : JST B8P-VH or equivalent

Pin No.	Assignment	Mating Housing	Terminal
1,2,3,4	+V	JST VHR or equivalent	JST SVH-21T-P1.1 or equivalent
5,6,7,8	-V		

Power Good Connector(CN3):JST B4B-XH or equivalent

Pin No.	Status	Mating Housing	Terminal
1	PG	JST XHP or equivalent	JST SXH-001T-P0.6 or equivalent
2	GND		
3	-S		
4	+S		

5VSB Connector(CN901) : JST B-XH or equivalent

Pin No.	Assignment	Mating Housing	Terminal
1	PS/ON	JST XHP or equivalent	JST SXH-001T or equivalent
2,4	GND		
3	5VSB		

⚠ HS1,HS2,HS3 can not be shorted

**Block Diagram**

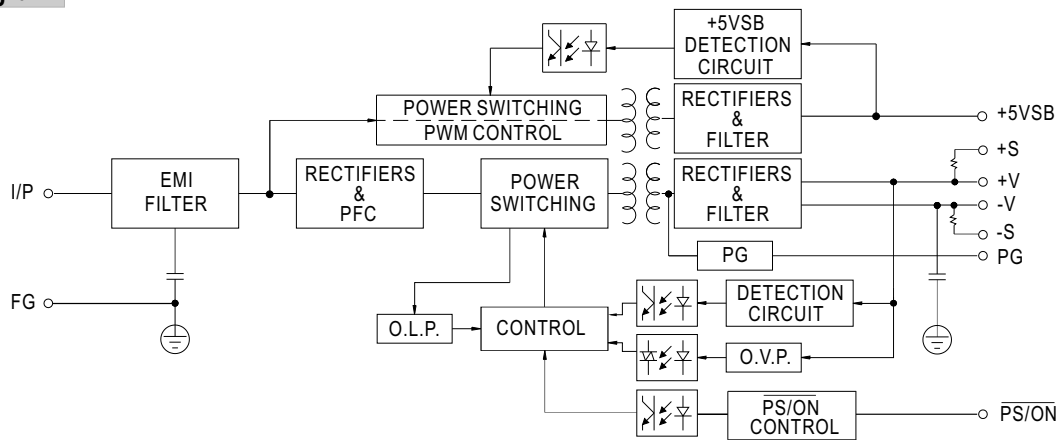

fosc :100KHz(5V)  
70KHz(12~48V)

**Derating Curve**

**Output Derating VS Input Voltage**

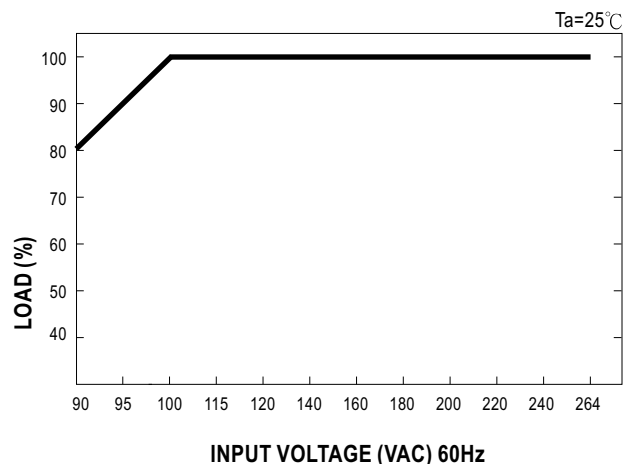
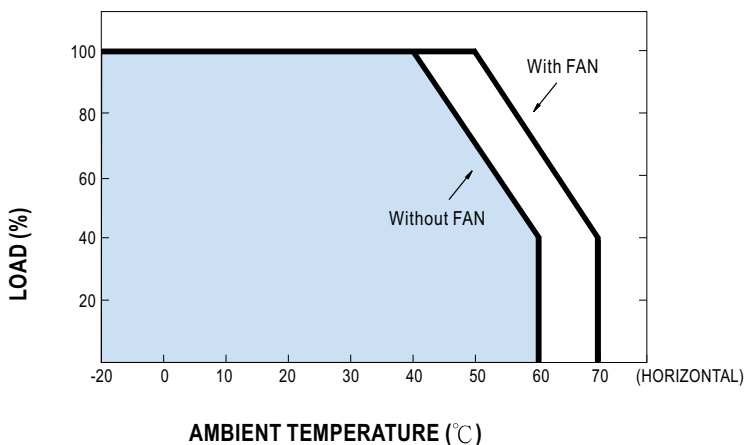

MODEL : RPSG-160-15

OUTPUT FUNCTION TEST

NO	TEST ITEM	SPECIFICATION	TEST CONDITION	RESULT	VERDICT
1	RIPPLE & NOISE	V1 : 120 mVp-p (Max)	I/P : 230VAC O/P : FULL LOAD Ta : 25°C	V1 : 108 mVp-p (Max)	P
2	OUTPUT VOLTAGE ADJUST RANGE	CH1 : 13.5 V- 16.5 V	I/P : 230 VAC I/P : 115 VAC O/P : MIN LOAD Ta : 25°C	13.005 V~ 17.206 V / 230 VAC 13.004 V~ 17.206 V / 115 VAC	P
3	OUTPUT VOLTAGE TOLERANCE	V1 : 3 %~ -3 % (Max)	I/P : 100 VAC / 264 VAC O/P : FULL/ MIN LOAD Ta : 25°C	V1 : 0.06 %~ -0.06 %	P
4	LINE REGULATION	V1 : 0.5 %~ -0.5 % (Max)	I/P : 100 VAC ~ 264 VAC O/P : FULL LOAD Ta : 25°C	V1 : 0.04 %~ -0.04 %	P
5	LOAD REGULATION	V1 : 1 %~ -1 % (Max)	I/P : 230 VAC O/P : FULL ~MIN LOAD Ta : 25°C	V1 : 0.04 %~ -0.04 %	P
7	SET UP TIME	230VAC : 1200 ms (Max) 115 VAC : 2500 ms (Max)	I/P : 230 VAC I/P : 115 VAC O/P : FULL LOAD Ta : 25°C	230VAC/ 975 ms 115VAC/ 1950 ms	P
8	RISE TIME	230VAC : 30 ms (Max) 115VAC : 30 ms (Max)	I/P : 230 VAC I/P : 115 VAC O/P : FULL LOAD Ta : 25°C	230VAC/ 9.9 ms 115VAC/ 9.9 ms	P
9	HOLD UP TIME	230VAC : 16 ms (TYP) 115VAC : 16 ms (TYP)	I/P : 230 VAC I/P : 115 VAC O/P : FULL LOAD Ta : 25°C	230VAC/ 31 ms 115VAC/ 24 ms	P
10	OVER/UNDERSHOOT TEST	< ±5%	I/P : 230 VAC O/P : FULL LOAD Ta : 25°C	TEST : < 5 %	P
11	DYNAMIC LOAD	V1 : 1500 mVp-p	I/P : 230 VAC O/P : FULL /Min LOAD 90%DUTY/1KHZ Ta : 25°C	417 mVp-p	P

## INPUT FUNCTION TEST

NO	TEST ITEM	SPECIFICATION	TEST CONDITION	RESULT	VERDICT
1	INPUT VOLTAGE RANGE	100VAC-264 VAC	I/P : TESTING O/P : FULL LOAD Ta : 25°C	73V-264V	P
			I/P : LOW-LINE-3V= 97V HIGH-LINE+15%=300 V O/P : FULL/MIN LOAD ON : 30 Sec. OFF : 30 Sec 10MIN (AC POWER ON/OFF NO DAMAGE)	TEST : OK	
2	INPUT FREQUENCY RANGE	47HZ -63 HZ NO DAMAGE OSC	I/P : 100 VAC ~ 264 VAC O/P : FULL-MIN LOAD Ta : 25°C	TEST : OK	P
3	POWER FACTOR	0.93 / 230 VAC(TYP) 0.98 / 115 VAC(TYP)	I/P : 230 VAC I/P : 115 VAC O/P : FULL LOAD Ta : 25°C	PF= 0.95 / 230 VAC PF= 0.99 / 115 VAC	P
4	EFFICIENCY	87% (TYP)	I/P : 230 VAC O/P : FULL LOAD Ta : 25°C	87%	P
5	INPUT CURRENT	230V/ 1.1 A (TYP) 115V/ 2 A (TYP)	I/P : 230 VAC I/P : 115 VAC O/P : FULL LOAD Ta : 25°C	I = 0.82 A/ 230 VAC I = 1.6 A/ 115 VAC	P
6	INRUSH CURRENT	230V/ 70 A (TYP) 115V/ 35 A (TYP) COLD START	I/P : 230 VAC I/P : 115 VAC O/P : FULL LOAD Ta : 25°C	I = 65 A/ 230 VAC I = 32 A/ 115 VAC	P
7	LEAKAGE CURRENT	EARTH LEAKAGE CURRENT<300 uA  PATIENT LEAKAGE CURRENT<100 uA	I/P : 264 VAC O/P : Min LOAD Ta : 25°C	FOR EARTH : L-FG : 140 uA N-FG : 140 uA  FOR PATIENT L-FG : 77 uA N-FG : 77 uA	P
8	No load power consumption	<0.75W/240VAC	I/P : 264 VAC O/P : NO LOAD PS/ON -GND SHORT Ta : 25°C	0.22 W/240VAC	P

## PROTECTION FUNCTION TEST

NO	TEST ITEM	SPECIFICATION	TEST CONDITION	RESULT	VERDICT
1	OVER LOAD PROTECTION	105 %~ 135 %	I/P : 230 VAC I/P : 115 VAC O/P : TESTING Ta : 25°C	123%/ 230 VAC 121%/ 115 VAC Hiccup Mode	P
2	OVER VOLTAGE PROTECTION	CH1 : 17.25 V~ 20.25 V	I/P : 230 VAC I/P : 115 VAC O/P : MIN LOAD Ta : 25°C	18.67V/ 230 VAC 18.66V/ 115 VAC Shut down Re- power ON	P
3	OVER TEMPERATURE PROTECTION	SPEC : TSW1 : 105 ± 5°C O.T.P. NO DAMAGE TSW2 : 90 ± 5°C O.T.P. NO DAMAGE	I/P : 230 VAC O/P : FULL LOAD	O.T.P. Active 1 · Shut down o/p voltage · recovers automatically after temperature goes down 2 · Shut down Re-power ON	P
4	SHORT PROTECTION	SHORT EVERY OUTPUT 1 HOUR NO DAMAGE	I/P : 264 VAC O/P : FULL LOAD Ta : 25°C	NO DAMAGE Hiccup Mode	P

## CONTROL FUNCTION TEST

NO	TEST ITEM	SPECIFICATION	TEST CONDITION	RESULT	VERDICT
1	POWER GOOD SIGNAL	DELAY 10ms ~ 500ms	I/P : 230 VAC I/P : 115 VAC O/P : FULL LOAD Ta : 25°C	88ms/ 230 VAC 89ms/ 115 VAC	P
2	POWER FAIL SIGNAL	> 1ms	I/P : 230 VAC I/P : 115 VAC O/P : FULL LOAD Ta : 25°C	3ms/ 230 VAC 3ms/ 115 VAC	P
3	PS-ON INPUT SIGNAL	Power on : PS-ON="Hi" or ">2V" Power off : PS-ON="Low" or "<0.5V"	I/P : 230 VAC O/P : FULL LOAD Ta : 25°C	PS-ON= 1.5 V PS-ON= 14 V	P
4	REMOTE SENSE	>0.3V	I/P : 230 VAC O/P : FULL LOAD Ta : 25°C	>0.3V	P



### SAFETY TEST

NO	TEST ITEM	SPECIFICATION	TEST CONDITION	RESULT	VERDICT
1	WITHSTAND VOLTAGE	I/P-O/P : 4 KVAC/min I/P-FG : 1.5 KVAC/min O/P-FG : 0.5 KVAC/min	I/P-O/P : 4.4 KVAC/min I/P-FG : 1.8 KVAC/min O/P-FG : 0.6 KVAC/min Ta : 25°C	I/P-O/P : 1.893 mA I/P-FG : 2.51 mA O/P-FG : 0.222 mA NO DAMAGE	P
2	ISOLATION RESISTANCE	I/P-O/P : 500VDC>100MΩ I/P-FG : 500VDC>100MΩ O/P-FG : 500VDC>100MΩ	I/P-O/P : 500 VDC I/P-FG : 500 VDC O/P-FG : 500 VDC Ta : 25°C /70%RH	I/P-O/P : 30 GΩ I/P-FG : 30 GΩ O/P-FG : 30 GΩ NO DAMAGE	P
3	GROUNDING CONTINUITY	FG(PE) TO CHASSIS OR TRACE < 100 mΩ	40 A / 2min Ta : 25°C / 70%RH	7 mΩ	P
4	APPROVAL	TUV : Certificate NO : UL : File NO :			N/A

### E.M.C TEST

NO	TEST ITEM	SPECIFICATION	TEST CONDITION	RESULT	VERDICT
1	HARMONIC	EN61000-3-2 CLASS A CLASS D	I/P : 230 VAC/50HZ O/P : FULL LOAD Ta : 25°C	PASS	P
2	CONDUCTION	EN55022 EN55011 CLASS B	I/P : 230 VAC (50HZ)115V/60HZ O/P : FULL/50% LOAD Ta : 25°C	PASS Test by certified Lab	P
3	RADIATION	EN55022 EN55011 CLASS B	I/P : 230 VAC (50HZ) O/P : FULL LOAD Ta : 25°C	PASS Test by certified Lab	P
4	E.S.D	EN61000-4-2 MEDICAL AIR : 8KV / Contact : 6KV	I/P : 230 VAC/50HZ O/P : FULL LOAD Ta : 25°C	CRITERIA A	P
5	E.F.T	EN61000-4-4 MEDICAL	I/P : 230 VAC/50HZ O/P : FULL LOAD Ta : 25°C	CRITERIA A	P
6	SURGE	IEC61000-4-5 MEDICAL	I/P : 230 VAC/50HZ O/P : FULL LOAD Ta : 25°C	CRITERIA A	P
7	Test by certified Lab & Test Report Prepare				

### M.T.B.F & LIFE CYCLE CALCULATION

NO	TEST ITEM	SPECIFICATION	TEST CONDITION	RESULT	VERDICT
1	CAPACITOR LIFE CYCLE	RPSG-160-5 WITH FAN : SUPPOSE I/P : 230VAC O/P : FULL LOAD I/P : 230VAC O/P : FULL LOAD	C106 IS THE MOST CRITICAL COMPONENT Ta= 25 °C LIFE TIME= 1456243 HRS Ta= 50 °C LIFE TIME= 196462 HRS		P
2	MTBF	MIL-HDBK-217F NOTICES2 PARTS COUNT TOTAL FAILURE RATE : 230.5 k HRS			P

## COMPONENT STRESS TEST

NO	TEST ITEM	SPECIFICATION	TEST CONDITION	RESULT	VERDICT
1	Power Transistor (D to S) or (C to E) Peak Voltage	Q 3 Rated 2SK3568 12A/500V	I/P : High-Line +3V = 267 V O/P : (1)Full Load Turn on (2) Output Short Ta : 25°C	(1) 448 V (2) 464 V	P
2	Diode Peak Voltage	Q101 Rated FMEN-2308 : 30A/80V	I/P : High-Line +3V = 267 V O/P : (1)Full Load Turn on (2)Output Short Ta : 25°C	(1) 77 V (2) 72 V	P
3	PFC Transistor (D to S) or (C to E) Peak Voltage	Q 1 Rated IRFP460A 20A/500V	I/P : High-Line +3V = 267 V O/P : (1)Full Load Turn on (2) Output Short Ta : 25°C	(1) 440 V (2) 424 V	P
4	Input Capacitor Voltage	C 5 Rated 120u/420V 105°C	I/P : High-Line +3V = 267 V O/P : (1)Full Load Turn on /Off (2) Min load Turn on /Off (3)Full Load /Min load Change Ta : 25°C	(1) 383.9 V (2) 384.8 V (3) 384.8 V	P
5	Control IC Voltage Test	U 1 Rated FAN4801 : 12V-30V	I/P : High-Line +3V = 267 V O/P : (1)Full Load Turn on /Off (2) Min load Turn on /Off (3)Full Load /Min load Change Ta : 25°C	(1) 14.365 V (2) 14.408 V (3) 14.408 V	P

DATE	SAMPLE	TEST RESULT	TESTER	APPROVAL
2008/9/17	RD SAMPLE	PASS	SANFORD SU	VINCENT TSENG
2009/3/11	PRODUCT SAMPLE W0810A12	PASS	SANFORD SU	VINCENT TSENG
2009/3/25	PRODUCT SAMPLE W0902B22	PASS	SANFORD SU	VINCENT TSENG

2003/12/12 A50-F023